

Clutch Basket Installation

1. Following the procedures in the OEM service manual, remove the existing clutch basket from the engine.
2. Remove the rivets holding the primary gear to the OEM aluminum clutch basket. The rivets can be removed by milling, drilling, or grinding the ends off and pressing them out.
CAUTION: When removing the OEM rivets, do not damage the steel gear, as it will be used with your new *Wiseco forged clutch basket*.
3. Remove all components from the OEM basket, taking note of how everything will be reassembled.
4. Install the OEM cushions, OEM gear, and new retainer plate onto the *Wiseco forged clutch basket*. (See illustration)
5. Install the new fasteners into the clutch basket assembly. Tighten to 65 in-lbs in a criss-cross pattern to compress the assembly evenly.
6. Place the assembled basket on a hard smooth surface, and using a hammer and punch, peen over the ends of the screws where they come through the bottom-inside of the clutch basket.
7. Install the new clutch basket assembly into the engine following the procedures in the OEM service manual.

WISECO
PRECISION FORGED TOUGH

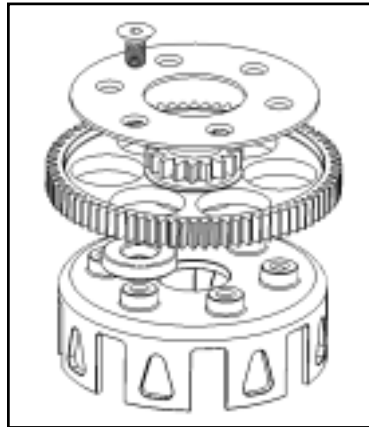

FC 7.5.1-1 Rev. A0